

# TÖYÖTÖMI

## PORTABLE KEROSENE HEATER OPERATION AND MAINTENANCE INSTRUCTIONS

MODEL **KS-R25**

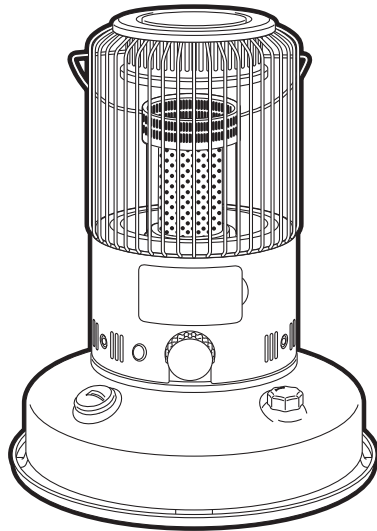

### **IMPORTANT**

READ AND UNDERSTAND INSTRUCTIONS BEFORE USING HEATER.

RETAIN INSTRUCTIONS FOR FUTURE REFERENCE.

This heater is designed to be used at altitudes up to 1,300m above sea level. Consult with your dealer otherwise.

### **CONTENTS**

SAFETY TIPS .....	1	ASSEMBLY AND OPERATION .....	6
FUEL GUIDE .....	3	CARE AND MAINTENANCE .....	10
OPERATING CONTROLS AND FEATURES .....	4	REPLACEMENT OF PARTS .....	11
SPECIFICATIONS .....	5	STORAGE .....	13
COMPONENT PARTS .....	5	TROUBLESHOOTING .....	14

# SAFETY TIPS

BEFORE OPERATING YOUR HEATER, PLEASE review these safety tips:

## ⚠ WARNING

### RISK OF EXPLOSION

1. NEVER use any fuel other than clean kerosene (paraffin).  
NEVER use gasoline (petrol). Use of gasoline (petrol) can lead to uncontrollable flames resulting in a destructive fire. Even kerosene (paraffin) contaminated with small amounts of gasoline (petrol), or similarly volatile materials, can be hazardous. NEVER use a can for kerosene (paraffin) that has previously been used for gasoline (petrol), paint thinner, or solvents.
2. The appliance is to be used only with paraffin, class C1 burner fuel in accordance with BS 2869 Part 2.
3. NEVER refill heater fuel tank when heater is operating or still hot. To do so may cause a "flash back" of flame to the fuel container, resulting in injury to yourself and your property.
4. NEVER use heater in areas where flammable vapors or gases may be present.  
Especially avoid use of heater where gasoline (petrol), naphtha, acetone or other volatile solvents are in the air, or whose containers are open. Such vapors could be ignited by the heater, resulting in fire and/or explosion.
5. NEVER fill heater fuel tank in living space. Fill heater tank outdoors. NEVER overfill your heater. Always replace heater tank cap securely after refueling. Spillage of kerosene (paraffin) produces strong odor which is hard to remove. Spillage on carpet can be ignited if match or some other ignition source contacts it.
6. NEVER store or transport kerosene (paraffin) in other than a metal or plastic container that is (1) acceptable for kerosene (paraffin), (2) non-red in color, and (3) clearly marked, "KEROSENE (PARAFFIN)". NEVER store kerosene (paraffin) in the living space. Picking up a gasoline (petrol) can by mistake when fueling is a major cause of heater fires.

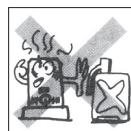
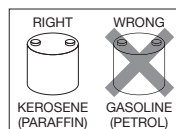

## ⚠ WARNING

### RISK OF BURNS OR FIRE

1. Observe the heater carefully for 15-20 minutes after start-up. Problems of improper adjustment of wick height or improperly seated heat chamber should become evident during this warm up period.

**NOTE:** Carefully follow the instructions for lighting and adjusting the flame.

2. Due to high surface temperatures, keep away from children, furniture and clothing.



3. DO NOT operate heater without protective guards completely attached.



4. DO NOT use heater to heat or boil water or as a cooking appliance. DO NOT place cooking utensils, tea kettles or any other object on top of heater while in operation.



5. DO NOT move, refuel or attempt to service your heater to avoid possible burns or fire while it is burning or still hot. If the heater is dropped while it is burning, fuel spillage and flames outside the heater may occur.

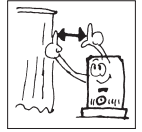

6. DO NOT operate heater less than one (1) meter from walls, draperies, clothing, or furniture. The operation of any heating appliance too close to such materials could cause them to ignite, possibly resulting in a serious fire.

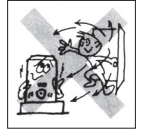

7. DO NOT operate your heater in areas exposed to strong drafts to avoid unstable burning. DO NOT operate heater in high-traffic areas such as doorways or hallways where it may be touched, jarred or tipped accidentally. DO NOT use the heater in a high wind.



8. DO NOT operate heater in direct sunlight to avoid overheating, which may cause abnormal flame behavior. DO NOT allow room temperature to go above 25-30°C. If the room temperature exceeds 25-30°C the flame may increase, thereby producing smoke.



9. Before going out, or at bedtime, turn the heater off, making sure the wick is in its lowest position (see EXTINGUISHING THE FLAME on page 9) and flame is completely extinguished.



**WARNING**

## RISK OF INDOOR AIR POLLUTION

Use heater only in well-ventilated areas. People with breathing problems should consult a physician before using the heater.

*"In a house of typical construction, that is, one that is not of unusually tight construction due to heavy insulation and tight seals against air infiltration, an adequate supply of air for combustion and ventilation is provided through infiltration. However, if the heater is used in a small room where less than 200 cubic feet (5.7m<sup>3</sup>) of air space is provided for each 1,000Btu per hour of heater rating (considering the maximum burner adjustment), the door(s) to adjacent room(s) should be kept open or a window to the outside should be opened at least 1 inch (25.4mm) to guard against potential buildup of indoor air pollution. DO NOT use the heater in a bathroom or any other small room with the door closed."*

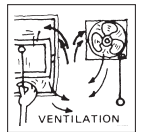

# FUEL GUIDE

The KS-R25 is designed for use with high-quality kerosene (paraffin) only. Use of low-quality kerosene (paraffin) will cause wick performance to drop, leading to “low flame” and “odor problem” conditions.

Purchase only kerosene (paraffin) in non-red cans reserved exclusively for kerosene (paraffin) and marked accordingly with the word “KEROSENE (PARAFFIN)”. Always store your kerosene (paraffin) in a separate area from where you store gasoline (petrol) for your power equipment, to avoid use of gasoline (petrol) in your heater.

## What to Buy...

- ALWAYS: Crystal clear, colorless, high quality KEROSENE (PARAFFIN).
- ALWAYS: Kerosene (paraffin) free of contaminants, water or cloudiness.
- NEVER: Gasoline (petrol), alcohol, white gas, camp stove fuel or additives.
- NEVER: Yellow or sour-smelling fuel.



## How to Use It...

- ALWAYS: Fill heater away from living quarters when heater is cool; use siphon.
- ALWAYS: Check wick frequently for tar build-up. (Rapid, heavy build-up may indicate poor quality or deteriorated fuel.)
- ALWAYS: Watch fuel gauge to avoid over-filling heater.

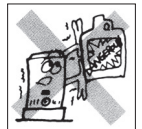

## How to Store It...

- ALWAYS: In a clean container, clearly marked KEROSENE (PARAFFIN).
- ALWAYS: Store away from direct sunlight, heat sources or extreme temperature changes.
- NEVER: In a glass container, or one that has been used for other fuels.
- NEVER: For longer than 6 months. (Begin each heating season with fresh kerosene (paraffin); discard at the end of the season.)



## Why It is Important...

Pure, clean kerosene (paraffin) is essential for safe and efficient heater operation. Poor quality or contaminated kerosene (paraffin) can cause:

- Low flame
- Excess tar deposits on the wick
- Reduced wick life
- Odor, smoke
- Difficulty in igniting or extinguishing flame

Use of a highly volatile flammable fuel such as gasoline (petrol) can produce uncontrollable flames, creating a severe fire hazard.



## CAUTION

Flames observed emerging from the heater body are a clear indication that fuel is dangerously contaminated with gasoline (petrol) or other highly flammable material. If this occurs,

- a. NEVER attempt to move the heater.
- b. Call the Fire Department.
- c. Use only a class “B” fire extinguisher.
- d. NEVER throw water directly on a burning heater.

# OPERATING CONTROLS AND FEATURES

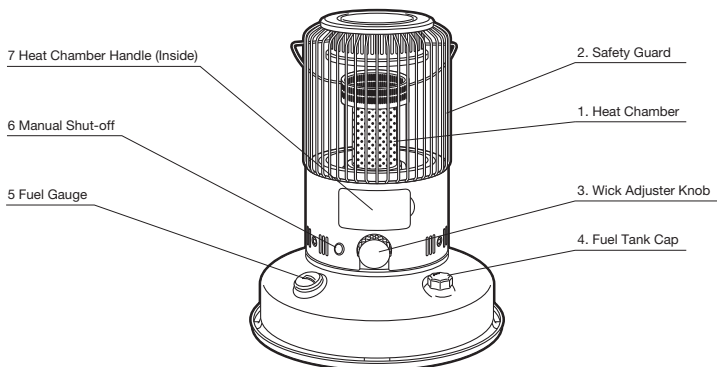

- 1. Heat Chamber:** Permits adjustment of heat output without increasing unwanted combustion materials or reducing combustion efficiency. This feature increases comfort and convenience while maximizing fuel saving.
- 2. Safety Guard:** Extensive grillework covers the hot surfaces of the heater, greatly reducing the possibility of accidental contact burns.
- 3. Wick Adjuster Knob:** Used to raise and lower wick for heat output adjustment. To extinguish flame turn knob counterclockwise.
- 4. Fuel Tank Cap:** Covers filling port of fuel tank.  
**NOTE:** Wipe away any spilled kerosene (paraffin) from tank after filling.
- 5. Fuel Gauge:** Indicates fuel level in tank.  
**NOTE:** Never fill beyond black line.
- 6. Manual Shut-off:** Used to rapidly retract wick and extinguish flame.  
**NOTE:** To avoid odor and smoke, do not use routinely to turn heater off. This manual shutoff is not effective when gasoline, gasoline (petrol)-contaminated kerosene (paraffin), or other highly flammable fuels are used in the heater.
- 7. Heat Chamber Handle:** Used to check and insure proper seating of the heat chamber after ignition. Improper seating of the heat chamber will cause erratic flame and smoke.

# SPECIFICATIONS

TOYOTOMI Portable Kerosene (paraffin) Heater Model KS-R25

Heat rating	8,600 BTU/h (2.5kW)
Fuel tank capacity	6.0 L
Burning time/tank*	24 Hours
Size (W × H × D)	388 × 475 × 388 mm
Weight	5.9 kg
Igniter	Automatic, powered by four (4) "C" size batteries

\* Depending on wick setting, condition and fuel quality.

# COMPONENT PARTS

REF#	PART NAME
1.	Carrying handle
2.	Top plate
3.	Guard assembly
4.	Battery holder cover
5.	Screw 3Z
6.	Glass cylinder
7.	Heat chamber assembly
8.	Wick adjuster assembly
9.	Pendulum assembly
10.	Wick adjuster knob
11.	Screw 1A
12.	Wing nut
13.	Glass fiber wick
14.	Rubber packing
15.	Main switch
16.	Igniter unit
17.	Screw 4A
18.	Access door
19.	Fuel tank assembly
20.	Fuel gauge
21.	Fuel tank cap
22.	Drip tray
23.	Battery holder

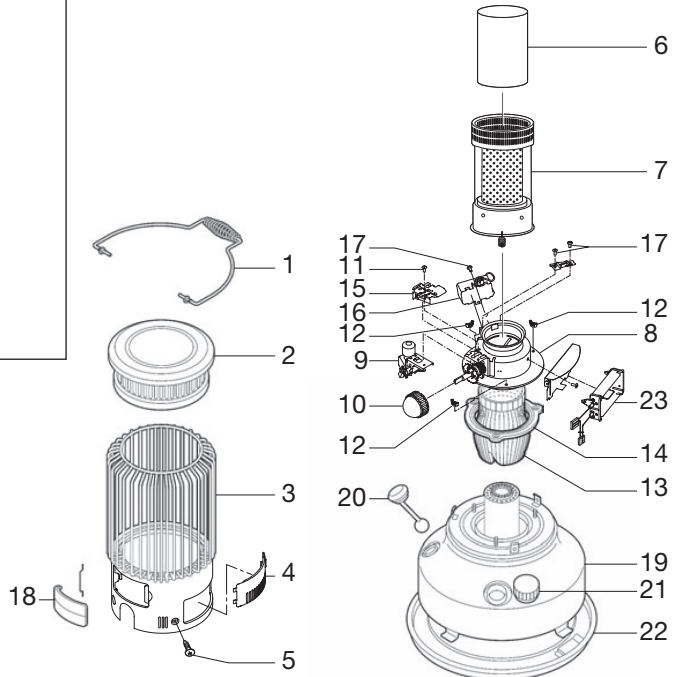

# ASSEMBLY AND OPERATION

## INSPECTION AND ASSEMBLY

**NOTE:** Save the shipping carton and packing materials for future storage of your heater.

### 1. REMOVE PACKING MATERIALS

Remove all packing materials from your heater and install the guard as follows:

**CAUTION:** Risk of fire. The packing materials are flammable.

a) Remove the carrying handle, top plate and packing materials.

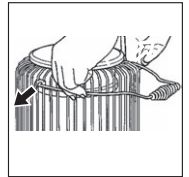

b) Replace the top plate and carrying handle.

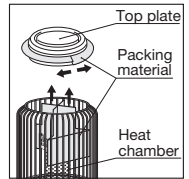

### 2. INSTALL DRIP TRAY

**CAUTION:** DO NOT operate your heater without the drip tray.

Place the drip tray on the floor.

Place the heater on the drip tray so the four (4) legs of the heater are next to the four (4) tabs on the tray.

Turn the heater clockwise until the feet slide into their tabs.

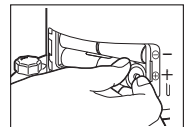
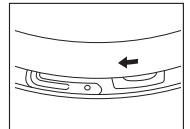

### 3. INSTALL BATTERIES

Locate the battery holder on the back of your heater. Remove the battery holder cover.

Insert the four (4) "C" size batteries according to the plus (+) and minus (-) markings inside the holder.

Replace the battery holder cover.

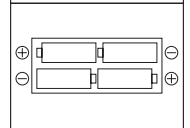

# FUELING

**⚠ WARNING:** Use only clean Kerosene (paraffin). NEVER use gasoline (petrol) or other flammable liquids. ALWAYS extinguish heater before refill heater fuel tank. Fuel heater outside the living area.

1. Insert the straight tube of the manual fuel siphon into the kerosene (paraffin) container. Remove the fuel tank cap on the heater, and insert the siphon's flexible hose into the fuel tank opening.
2. Turn the air vent knob on the top of the siphon clockwise to close the air vent.
3. To start the flow of kerosene (paraffin), squeeze the bulb of the siphon vigorously six or seven times. Once the flow begins, it is no longer necessary to squeeze the bulb. To avoid overfilling the tank, watch the fuel gauge. As the indicator enters the red zone, stop the flow by turning the air vent knob counterclockwise.

**NOTE:** Be especially careful to avoid overfilling the tank with very cold kerosene (paraffin); otherwise overflow might occur when the fuel warms up.

4. Remove the siphon carefully, allowing the excess kerosene (paraffin) to drain from the tube back into container. Replace the fuel tank cap and tighten it securely. Be sure to wipe away any spilled kerosene (paraffin) from tank or other heater parts.

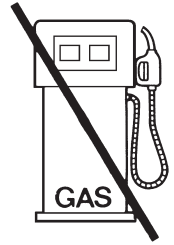

USE KEROSENE ONLY  
(PARAFFIN)

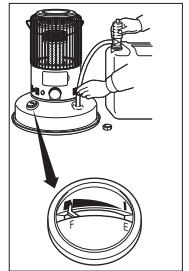

# CHECK BEFORE LIGHTING

## 1. LOCATE YOUR HEATER AWAY FROM WALLS AND AVOID DRAFTS

Allow at least one (1) m of clearance between the heater and walls, curtains, shelving or other combustible materials. DO NOT operate your heater in drafty areas or locations where opening doors may create gusts of air. Drafts or strong air currents may make flame unstable and affect heater performance.

## 2. LEVEL THE HEATER

The heater should be operated on a firm, level floor.

**NOTE:** If your heater is not level, change locations. DO NOT attempt to prop it up with books or other objects. An unlevel heater may burn with an uneven flame.

## 3. ENGAGE THE AUTOMATIC EXTINGUISHER

The automatic extinguisher is engaged automatically by turning the wick adjuster knob clockwise. Check the operation of the automatic extinguisher before lighting your heater. After turning the wick adjuster knob clockwise until it stops, turn the manual shutoff counterclockwise to be sure the wick moves smoothly down.

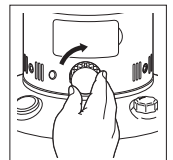



# LIGHTING

**NOTE:** When you first use your new heater, ignite it out of the living area of your house, either in a garage or an outside area protected from strong drafts. Burn it for about 15 minutes to remove all of the protective oil present on the burner parts. If this 15 minutes “burn-in” is done inside, some objectionable odor will be observed. This procedure is necessary **ONLY THE FIRST TIME** you ignite your heater.

**NOTE:** If you have fueled your heater for the first time, or if you are refueling it after it has been out of fuel for a long time, you will need to wait about thirty (30) minutes for the wick to become fully saturated before lighting. Failure to allow enough time for the wick to become fully saturated may cause permanent damage to the wick when it is lighted.

1. Turn the wick adjuster knob clockwise until it stops.

It makes a spark discharge sound in the process of lighting procedure, but turn the wick adjuster knob clockwise until it stops.

As the wick rises within the heater, the wick adjuster knob turns with some resistance and makes a sound like the winding of a clock. Once the wick has reached its proper height, the automatic extinguisher is fully engaged.

The wick adjuster knob can now move freely left or right to adjust the flame.

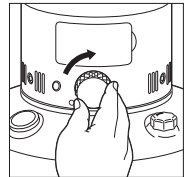

2. LIGHTING WITH A MATCH

You should not have to light the heater with a match, but should it become necessary, open the access door, lift the heat chamber up by holding the heat chamber handle and touch the match to the top of the wick. **DO NOT** allow burned parts of the match to fall or remain on the wick.

**NOTE:** To restore the automatic igniter system to proper operation, replace worn-out batteries.

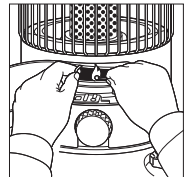

3. Be sure that heat chamber is properly seated by moving the heat chamber handle left and right, and close the access door.

**NOTE:** An improperly seated heat chamber can cause high flame, smoke, and potential damage to the heater itself. **DO NOT** leave the heater until you have determined that the flame is burning normally, as described in the following section.

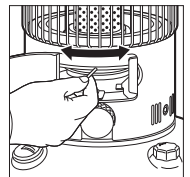

# ADJUSTING THE FLAME

1. After lighting, wait for the heat chamber to reach operating temperature. This will take ten-fifteen minutes, then the flame will be visible.

## 2. CHECK THE FLAME LENGTH

Look at the flame and check its length. Flame length is not necessarily even or uniform around the circumference of the center disk. Some areas may be lower than others, but on maximum wick height, flame length should average between 10 mm (3/8 in.) to 30 mm (1 3/16 in.).

If necessary, raise or lower the wick by turning the wick adjuster knob to produce the proper flame condition.

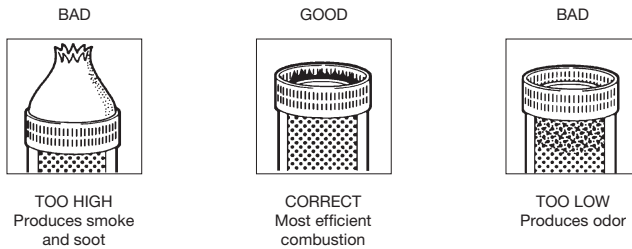

**NOTE:** DO NOT operate your heater with wick set TOO LOW or TOO HIGH. Doing so will decrease combustion efficiency and increase production of unwanted emissions.

**NOTE:** ALWAYS observe the heater closely for the first 15-20 minutes after it is lighted to be sure it is properly adjusted.

# EXTINGUISHING THE FLAME

1. Turn the wick adjuster knob counterclockwise until it stops (about 3/4 turn). Within a few moments, the flame will be completely extinguished and the heater will be off.
2. Make sure the flame is out completely.
3. DO NOT try to relight the heater for at least three (3) minutes after turning it off, as this may cause smoke and odor.

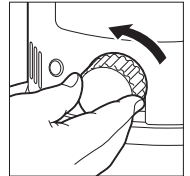

# MANUAL SHUTOFF

When quick shutoff is necessary, push the manual shutoff.

**NOTE:** For routine turn-off, DO NOT use the “Manual Shutoff” or activate the “Automatic Extinguisher” by jarring the heater. These methods may cause unwanted odor, soot and smoke. Only the wick adjuster knob should be used for normal shutoff.

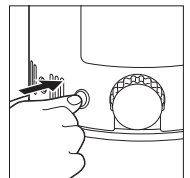

# CARE AND MAINTENANCE

As with any good appliance, preventive as well as corrective maintenance is occasionally required. Please read the following section carefully in order to enjoy the greatest benefits from your heater.

## INSPECTION OF THE WICK

**NOTE:** One of the simplest but also the most important components of your heater is the wick.

With proper attention, the wick will last at least one heating season and, depending on the quality of the fuel used, possibly longer, it helps to perform routine maintenance operations of the wick.

1. Indications that the wick may need attention are:

- low flame
- tar deposit on the top edge of the wick
- difficulty in turning the wick adjuster knob
- a flickering or dying flame

2. Clean the wick by burning dry as follows:

1) When the fuel gauge indicates empty, but the heater is still burning, raise the wick to its highest position and allow the flame to consume the remaining fuel in the tank.

**NOTE:** Burning the wick dry can at times create odors. For the burning dry procedure, remove your heater from the living area of your house into a well-ventilated area such as a garage or even a sheltered area outside. If you burn the wick dry outside, be sure that the heater is not exposed to strong drafts during the procedure.

2) After the heater has cooled completely, remove the heater cover as described in items 1 and 2 of the next section.

3) Remove any residue from the wick with a small brush such as an old toothbrush. Cinders or soot in the burner around the wick may be vacuumed away. Be careful when removing such material from the wick with a brush, to do so gently so as not to tear the top surface of the wick.

4) Remove any tar deposits on the top of wick adjuster and primary air tube using a scraper.

**NOTE:** When good wick performance is no longer achieved by the burning dry process, it may be necessary to replace the burned wick with a new one.

5) Before reassembling the heater, take a few minutes to wipe the parts with a soft cotton cloth or paper towels.

6) Reassemble the heater, following directions in item 11 of the next section.

**NOTE:** If the flame is still low after cleaning the wick, the wick may contain some water. It is then necessary to replace the wick and empty all kerosene (paraffin) from the fuel tank. Dry the tank thoroughly and refill with fresh, pure kerosene (paraffin).

## CLEANING THE HEATER

1. Cleaning the outer cover and the fuel tank.

Wipe the surface of the outer cover and the fuel tank with a soft cloth.

Stains can be removed with a cloth and a mild soapy solution.

DO NOT use scouring pads, or harsh abrasives

2. Chrome guard

A non-abrasive metal polisher can be used with a soft cloth to polish the guard.

3. Heat chamber

Loose cinders or soot on the heat chamber can be brushed away.

# CHECKING THE AUTOMATIC EXTINGUISHER

Test the operation of the automatic extinguisher weekly. A good time to check is before lighting the heater.

1. Turn the wick adjuster knob clockwise until it stops (the same way as to light the heater).
2. Push the manual shutoff and make sure the wick has dropped.
3. Repeat step 1 and then shake the heater and make sure the automatic extinguisher worked.

## REPLACEMENT OF PARTS

### REPLACING THE WICK

USE ONLY GENUINE TOYOTOMI REPLACEMENT WICK. SUBSTITUTE WICKS CAN SEVERELY REDUCE PERFORMANCE AND SAFETY.

**⚠ WARNING:** Before disassembling your heater, allow it to cool completely.

1. Release the automatic extinguisher by pushing down on the manual shutoff.

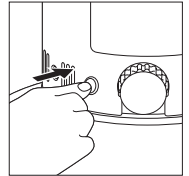

2. Remove the three (3) screws holding the outer cover by using the screwdriver, and lift cover off. Remove batteries from the battery holder.

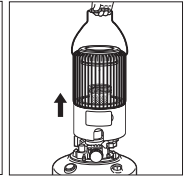
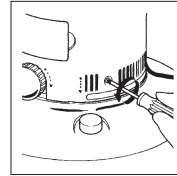

3. Remove the heat chamber.

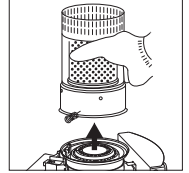

4. Remove the three (3) wing nuts around the wick adjuster. Lift the wick adjuster off the heater while moving it slightly back and forth.

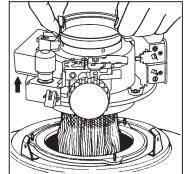

5. Slide two fingers between the wick and the wick adjuster. Lift the pins in the wick off the slots. After lifting all three (3) pins off the slots, fold the wick and remove it.

**NOTE:** DO NOT damage the electrodes of Igniter unit on the Wick Adjuster at the time of replacing the wick.

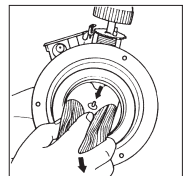
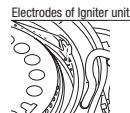

6. Place the wick adjuster on its side. Next, line up the two (2) openings in the wick adjuster: 1) the diagonal slots in the fixed part of the wick adjuster, and 2) the slots in the moving part of the wick adjuster controlled by the wick adjuster knob.

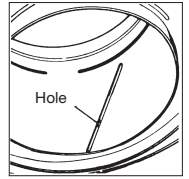

7. Fold the new wick in quarters and insert it into the wick adjuster from wick adjuster bottom. Place one of the pins in one of the lined-up openings. If you experience difficulty, gently turn the wick adjuster knob clockwise. Then insert the two other pins, turning the wick adjuster knob if necessary.

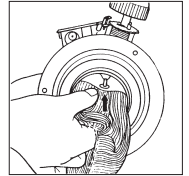

8. Finally, gently press the wick, all along its circumference, against the wick adjuster to insure that it is firmly in place.

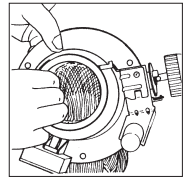

9. Lower the wick adjuster into the fuel tank, guiding the tail of the wick so it fits over the primary air tube and evenly into place.

Point the wick adjuster knob to the front of the heater. Insure that the wick adjuster is centered over the studs on the fuel tank.

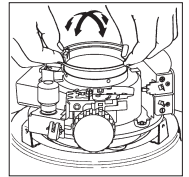

**NOTE:** The space between the wick adjuster and the primary air tube should be even all around.

**NOTE:** Make certain the top of the wick adjuster and the top of primary air tube are the same height. If they are uneven, the flames tend to be uneven, too.

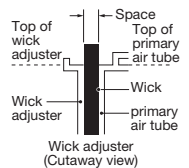

10. Tighten the three (3) wing nuts around the wick adjuster.

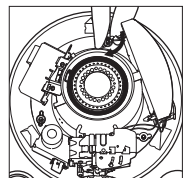

11. Turn the wick adjuster knob to be sure the wick moves smoothly up and down.

AFTER REPLACING THE WICK, CHECK THE OPERATION OF THE AUTOMATIC EXTINGUISHER.

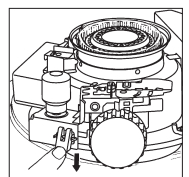
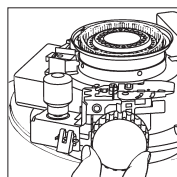

Wick height on position should be 6 mm (15/64 in.) when wick adjuster knob is turned fully clockwise. Be sure to check.

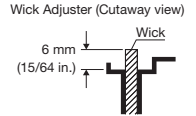

12. Install the heat chamber.

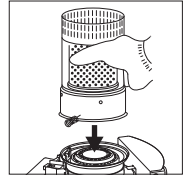

13. Replace the outer cover on the fuel tank and secure it into position with three (3) screws by using the screwdriver.

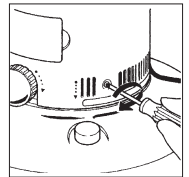

14. Grasp the heat chamber handle, then turn the heat chamber left and right to make sure that it is properly seated. Once again, check the proper operation of the automatic extinguisher. Replace batteries in the battery holder.

**NOTE:** Before lighting a new wick for the first time, turn the wick to its lowest position and allow the wick to saturate with kerosene (paraffin) for about thirty (30) minutes.

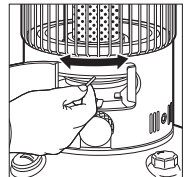

## STORAGE

At the end of each heating season, or when you do not plan to use your heater for an extended period of time, the following procedures are recommended.

### 1. CLEAN WICK AND HEATER

Follow directions in item 2 under "INSPECTION OF THE WICK".

### 2. DRAIN FUEL TANK

After you have burned your heater dry, a small amount of kerosene (paraffin) will remain in the fuel tank. It should be removed in order to avoid contamination when the heater is refueled at a later date. To do this, remove the fuel cap, tip the heater toward you and insert a small syringe into the bottom-most portion of the fuel tank. Empty the tank completely before storage.

### 3. REMOVE BATTERIES FROM BATTERY HOLDER

### 4. STORE HEATER

The original shipping carton is the best place to store your heater. If you do not have original packing materials, cover the heater with a large plastic bag and store in a dry place.

# TROUBLESHOOTING

PROBLEM	CAUSE	SOLUTION	PAGE
Wick fails to ignite	Out of fuel	Check fuel gauge; add fuel if necessary.	7
	Electrode does not spark	Check wire connections. Replace batteries.	6
	Water in kerosene (paraffin)/ poor quality kerosene (paraffin)	Drain tank. Install new wick. Refill with fresh, clean kerosene (paraffin).	11
Smoke or odor	Heat chamber tilted or improperly seated	Move heat chamber handle until heat chamber is properly seated and moves smoothly left and right.	8
	Wick set too high	Reduce wick height by turning wick adjuster knob counterclockwise.	9
	Dirty wick	Clean wick as described under "Care and Maintenance".	10
	Drafts	Relocate heater.	2
	Contaminated fuel/poor quality kerosene (paraffin)	Drain tank and rinse with clean kerosene (paraffin). Install new wick and refill with fresh, clean kerosene (paraffin).	10 11
Flickering, dying or low flame	Dirty wick	Clean wick as described under "Care and Maintenance".	10
		If necessary, install new wick.	11
	Water in kerosene (paraffin)/ poor quality kerosene (paraffin)	Drain tank and rinse with clean kerosene (paraffin). Install new wick and refill with fresh, clean kerosene (paraffin).	10 11
Wick adjuster knob is hard to turn	Dirty wick	Clean wick as described under "Care and Maintenance".	10
	Poor quality kerosene (paraffin)	Drain tank and rinse with clean kerosene (paraffin). Install new wick and refill with fresh, clean kerosene (paraffin).	10 11
	Damaged mechanism	Contact your dealer for service.	
Flame too high	Fuel contaminated with gasoline (petrol) or other highly flammable material	IMMEDIATELY shut off heater.	3
		Inspect all components for damage.	
		Drain tank and rinse with clean kerosene (paraffin). Install new wick and refill tank with fresh, clean kerosene (paraffin).	10 11

***TŌYŌTŌMI***

**TOYOTOMI CO., LTD.**

5-17, Momozono-cho  
Mizuho-ku, Nagoya, Japan

[www.toyotomi.jp](http://www.toyotomi.jp)

New 11/21

Printed in Japan  
0606000903